

## Orbital welding (Open heads)

**AXXAIR**

INNOVATIVE ORBITAL SOLUTIONS

Our range of open welding heads (SATO series) allows you to make very high quality welds in a minimal space.

On these heads you will find a mechanical tracking system to keep a constant arc height. The torch can tilt to weld at an angle.

Open heads are mainly recommended for the agro-food, pharmaceutical, chemical sectors, for wall thicknesses less than but also greater than 3 mm.

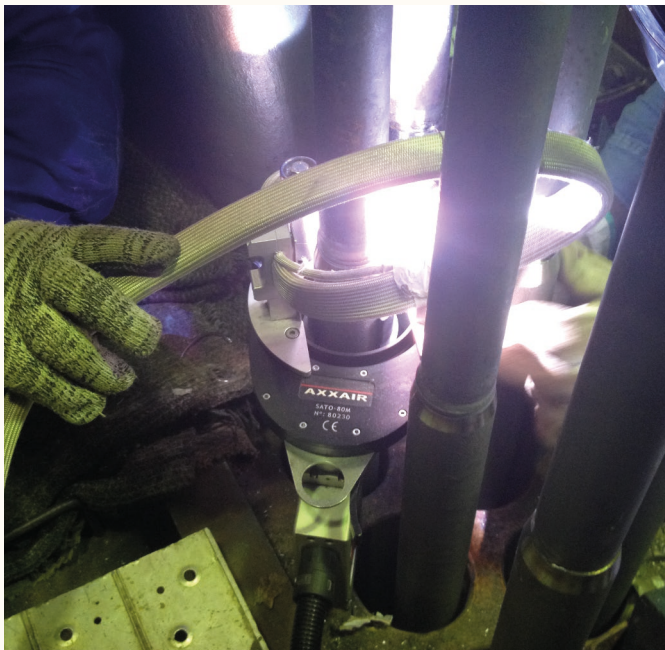

This type of machine can be used to weld carbon steel tubes.

Open heads offer very wide welding possibilities thanks to the inclination of the torch and the addition of filler metal. The clamping range is achieved without the addition of jaws.

The tracking system is by roller so as not to scratch the tube. All the parts in contact with the tube are made of stainless steel so as not to contaminate it.

With its unique symmetrical clamping system, its stepping motor control, this range offers a very wide range of use.

You can choose between heads provided with or without an AVC/OSC system.

### FLEXIBILITY, PRODUCTIVITY

AXXAIR open heads are available with or without filler metal. They have an optimized rotation sweep and 2 positions of feed motor to choose from. High duty cycle (water cooled torch).

### QUALITY AND REPEATABILITY

The SATO range is connected to our orbital generators, which permanently control all the welding parameters, guaranteeing repeatable and quality welds.

### PORTABILITY

In order to allow you to weld in restrictive conditions and locations, the size of rotating elements and the weight of the machines have been optimized. Our machines are supplied with integrated remote control and 5 m welding cable allowing the operator to work remotely from the generator.

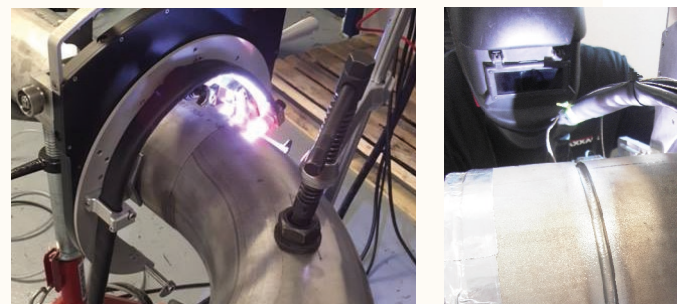

Please do not hesitate to contact us for all enquiries relating to orbital welding technology.

We will be glad to share our know-how with you and to devise a solution that best meets your needs!

Join **experience**



# SATO-40 - 80 - 115 - 170 - 220

**AXXAIR**  
INNOVATIVE ORBITAL SOLUTIONS

## Water Cooled



## Roller mechanical profile tracking

Constant arc voltage without marking the tube

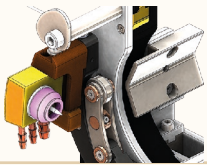

## Compatible with the SAXX power sources



## Transport

These heads are delivered in shock-proof, waterproof and dustproof cases



## Straight or Angled motor Symmetrical clamping

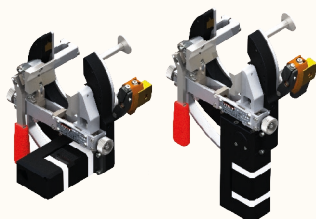

## Axial Adjustment

Wheel for axial adjustment of the position of the electrode

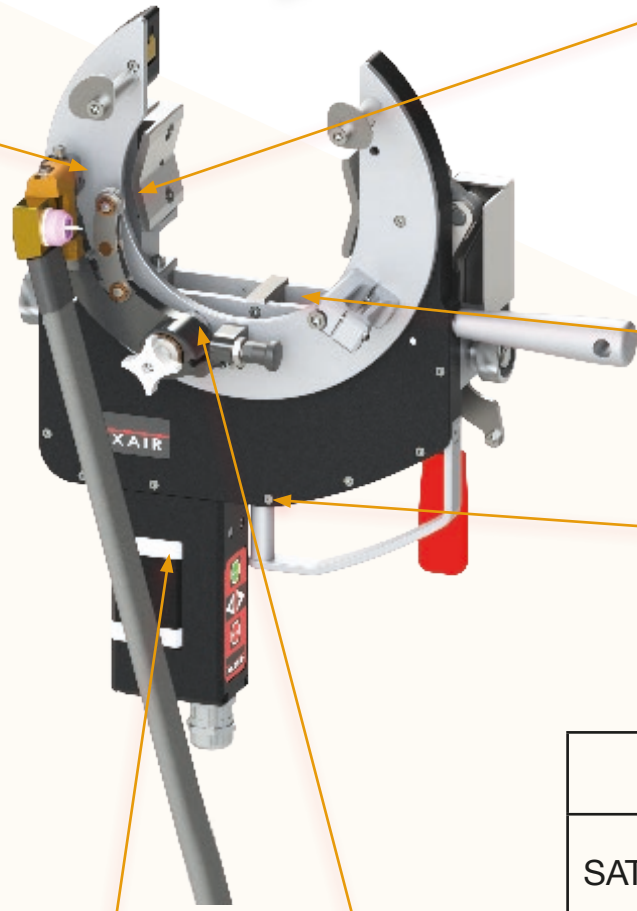
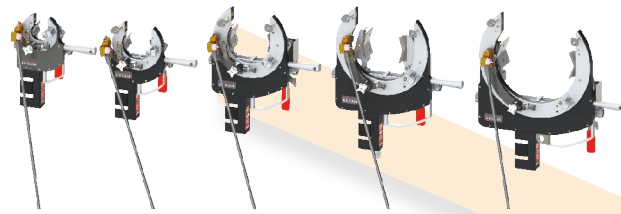

## Protection

High protection against arcing outside the electrode

## Torch angle adjustment

Welding flanges and short T angle

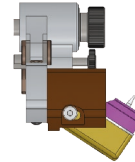

## Locked open position

## Motorization with encoder

Allows STARTING IN ALL ANGULAR electrode positions

Welding range	
SATO 40	∅ 10 - ∅ 40 mm 0.4- 1.5 "
SATO 80	∅ 19 - ∅ 80 mm 0.75 - 3 "
SATO 115	∅ 19 - ∅ 115 mm 0.75 - 4.5 "
SATO 170	∅ 25 - ∅ 170 mm 1 - 6.625 "
SATO 220	∅ 38 - ∅ 220 mm 1.5 - 8.265 "



Join **experience**



# SATO-40 - 80 -115 - 170 -220



## Technical characteristics:

- WATER cooled head
- Mechanical profile tracking: constant arc height without marking the tube
- Quick symmetrical tightening by lever
- Motorization with encoder: allows starting from any angular position of the electrode
- Wide diameter range
- Inclination and axial adjustment of the electrode
- Small rotation sweep from the centre of the tube
- Compact design

## Choice of two different models (to choose according to your applications)

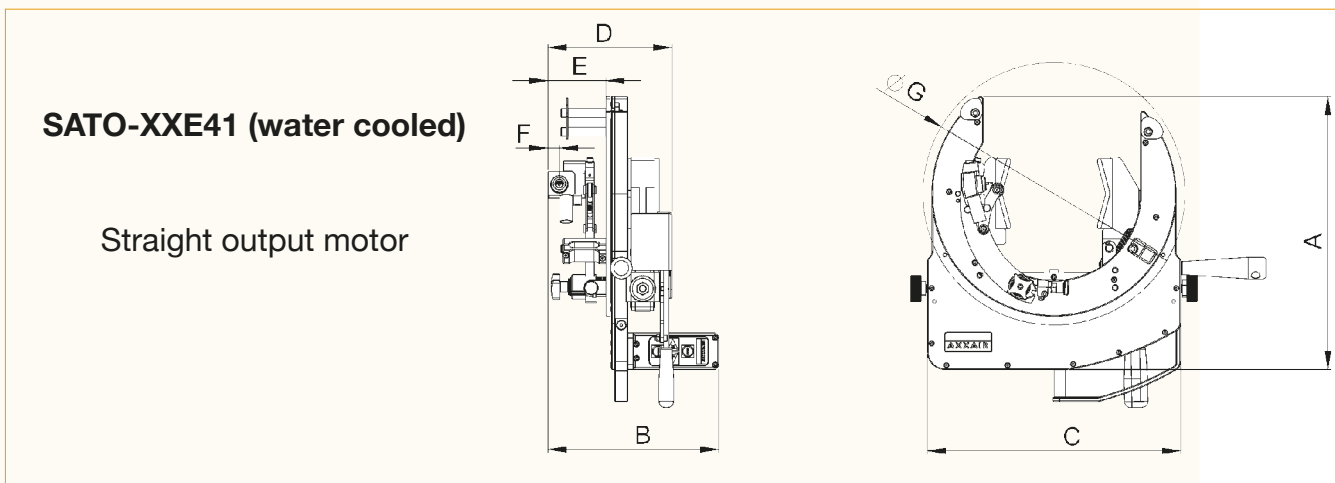
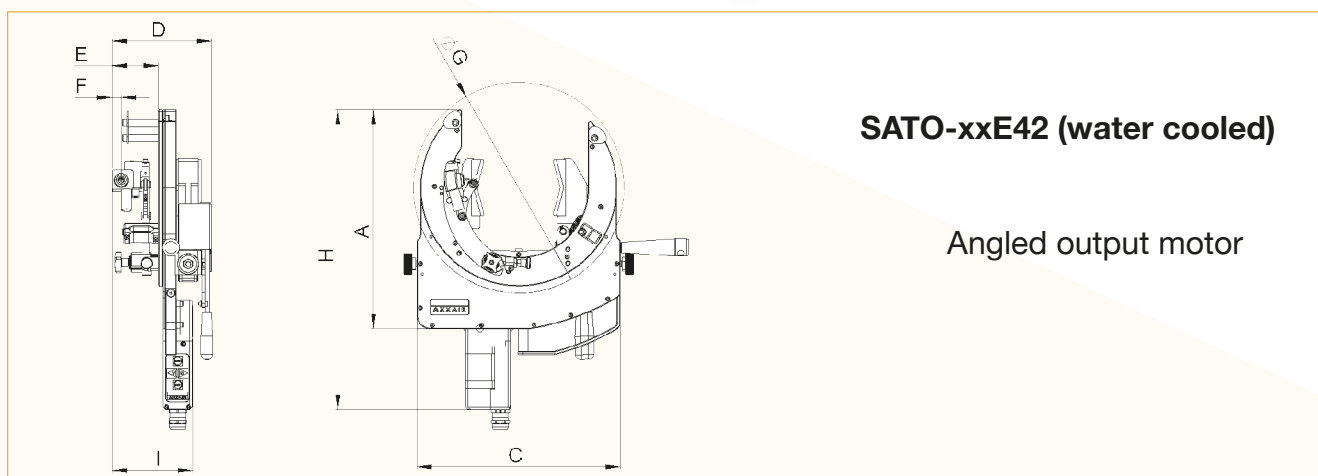

	A mm	B mm	C mm	D mm	E mm	F mm	G mm	H mm	I mm
<b>SATO-40</b>	169	183 to 191	142	116 to 126	57 to 67	13	Ø140	270	113 to 121
<b>SATO- 80</b>	181	186 to 196	160	116 to 126			279		
<b>SATO-115</b>	265	186 to 196	230	133 to 143			Ø224	363	
<b>SATO-170</b>	312	186 to 196	290	133 to 143			Ø294	410	
<b>SATO-220</b>	353	186 to 196	350	133 to 143			Ø350	451	



Join **experience**



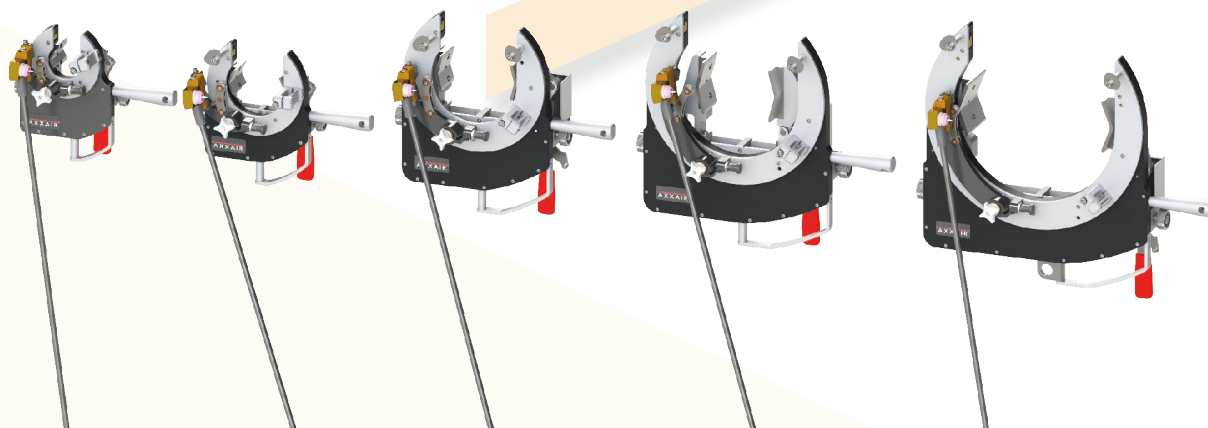

**SATO-40 - 80 - 115 - 170 - 220****AXXAIR**  
INNOVATIVE ORBITAL SOLUTIONS

Moteur	Cooling	Product Code	Welding machine for tubes of the following diameters (in mm)	Net weight	Dimensions (AxBxC in mm)
<b>Angled motor</b>	<b>WATER</b>	SATO-40E42	ø 10 - ø 40 mm	3.8 kg	169 x 183 x 142
		SATO-80E42	ø 19 - ø 80 mm	4.2 kg	181 x 186 x 160
		SATO-115E42	ø 19 - ø 115 mm	6.7 kg	265 x 186 x 230
		SATO-170E42	ø 25 - ø 170 mm	8 kg	312 x 186 x 290
		SATO-220E42	ø 38 - ø 220 mm	9.4 kg	353 x 186 x 350
<b>Straight motor</b>	<b>WATER</b>	SATO-40E41	ø 10 - ø 40 mm	3.8 kg	169 x 191 x 142
		SATO-80E41	ø 19 - ø 80 mm	4.2 kg	181 x 196 x 160
		SATO-115E41	ø 19 - ø 115 mm	6.7 kg	265 x 196 x 230
		SATO-170E41	ø 25 - ø 170 mm	8 kg	312 x 196 x 290
		SATO-220E41	ø 38 - ø 220 mm	9.4 kg	353 x 196 x 350



# AXXAIR's orbital welding

## Sweep Multi-pass TIG welding

### - AVC/OSC system -

**AXXAIR**

INNOVATIVE ORBITAL SOLUTIONS

#### Motorised voltage control: AVC

Motorised Arc Voltage Control is often abbreviated to AVC. Arc voltage is directly linked to the distance between the tube to be welded and the electrode. In other words, this option ensures the correct tube-electrode distance is maintained electronically during welding.

AVC can indeed be of huge benefit, especially in mechanised welding, and the more sensors there are to guide the machine, the less user intervention is required.

#### The two most frequent applications:

- When you do not wish to measure the external diameter physically using a feeler probe; AVC requires no contact with the tube and the sensor is more accurate and responsive than with physical tracking.

- When wire welding and the deposition rate beneath the electrode is not fully controlled, this can obviously affect the arc length. In this case, AVC means you never go near the soldering bath.

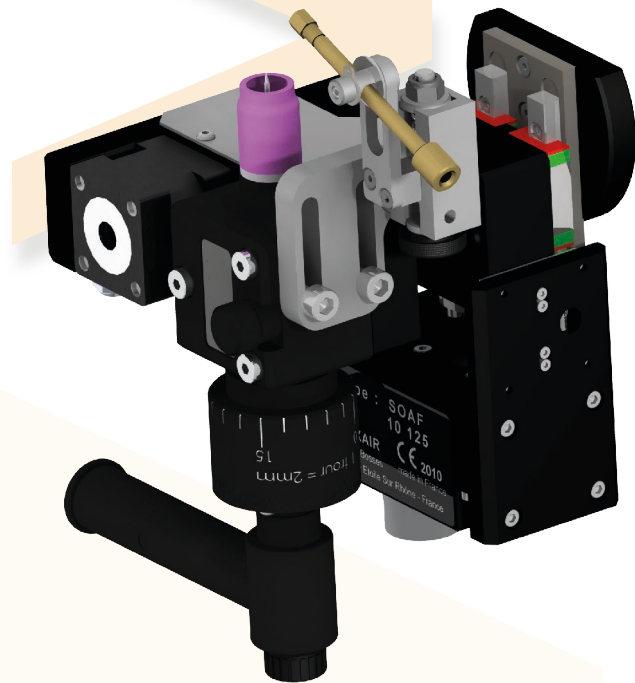
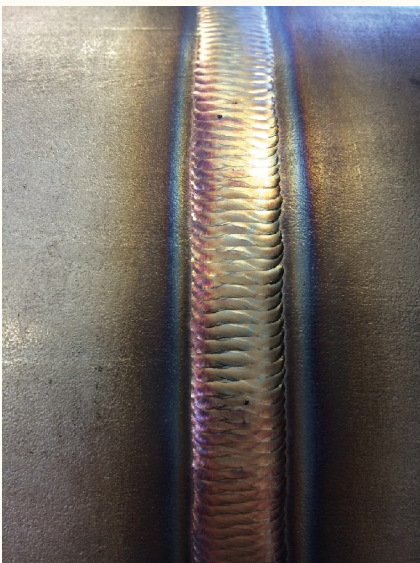

#### Fusion+OSC+wire:

This welding method combines AVC movement with oscillation of the torch and wire. This method is used for multi-pass welding of high thickness materials.

Torch oscillation is where the electrode is swung left and right in a linear motion so that each side of the joint can be kept liquid as welding progresses.

Oscillation brings an improvement in the number of passes, and therefore significantly improves productivity.

This system, when combined with AVC, is the only effective way of filling a tulip joint in multi-pass TIG welding.

**These systems are available on prefabrication machines and open heads.**



# SATO-115 - 170 -220 (AVC/OSC)



### Control of the wire

Regulation of the wire by the SAXX power sources

### Water Cooled

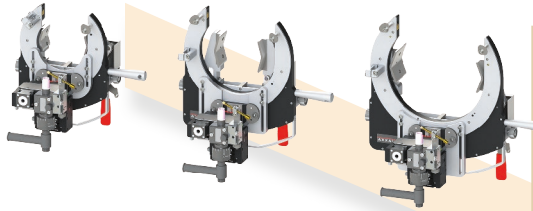

### Protection

High protection against arcing outside the electrode

### Multi-pass welding

#### Mortorised axial sweep (OSC)

Movement of the electrode's axial position: +/- 10 mm

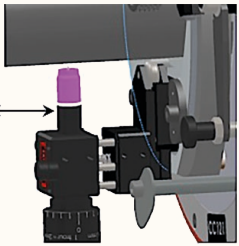

### Transport

These heads are delivered in shockproof, waterproof and dust-proof cases



### Constant distance: electrode-tube

#### Motorised setting and control of the distance tube-electrode (AVC)

regulates the arc voltage, the distance between the electrode and the tube

### Motorization with encoder

Allows STARTING IN ALL ANGULAR electrode positions

### AVC/OSC system

Allows to weld tubes with up to 12.7 mm wall thickness

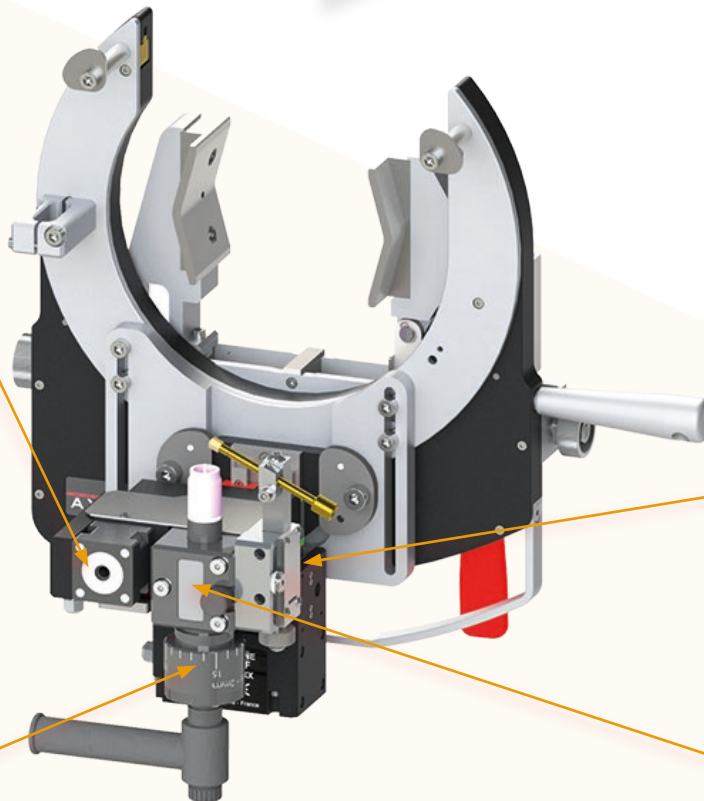

### Straight or Angled motor Symmetrical clamping

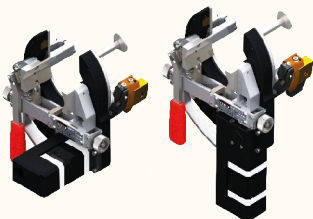

### Compatible with the 210 and 300 SAXX power sources

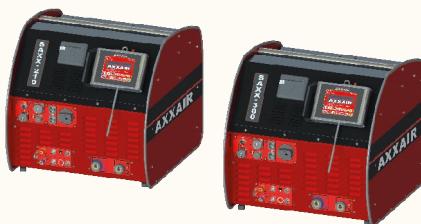

### Welding range

SATO 115	∅ 19 - ∅ 115 mm 0.75 - 4.5 "
SATO 170	∅ 25 - ∅ 170 mm 1 - 6.625 "
SATO 220	∅ 38 - ∅ 220 mm 1.5 - 8.265 "



# SATO-115 - 170 -220 (AVC/OSC)



## Caractéristiques techniques:

- WATER cooled head with AVC/OSC system
  - Quick symmetrical tightening by lever
  - Motorization with encoder: allows starting from any angular position of the electrode
  - Wide diameter range
  - For optimum use, the ambient temperature must be between 0 °C and + 40 °C.
  - Oscillation range: 20 mm, AVC range: 20 mm, max speed: 15 mm/s
- Machines compatible with AXXAIR welding power sources with SAXX (210 and 300) type liquid coolant system for welding cycle.

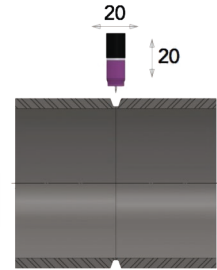

## Choice of two different models (to choose according to your applications)

**SATO-xxE52 (water cooled with AVC / OSC system)**

Angled output motor

**SATO-xxE51 (water cooled with AVC / OSC system)**

Straight output motor

	A mm	B mm	C mm	D mm	E mm	F mm	G mm	H mm	I mm
SATO-115	171	246-271	230	146-171	85-110	31.5	680	269	194-219
SATO-170	201		290				750	299	
SATO-220	220		350				800	318	



Join **experience**





# SATO-115 - 170 -220 (AVC/OSC)

**AXXAIR**  
INNOVATIVE ORBITAL SOLUTIONS

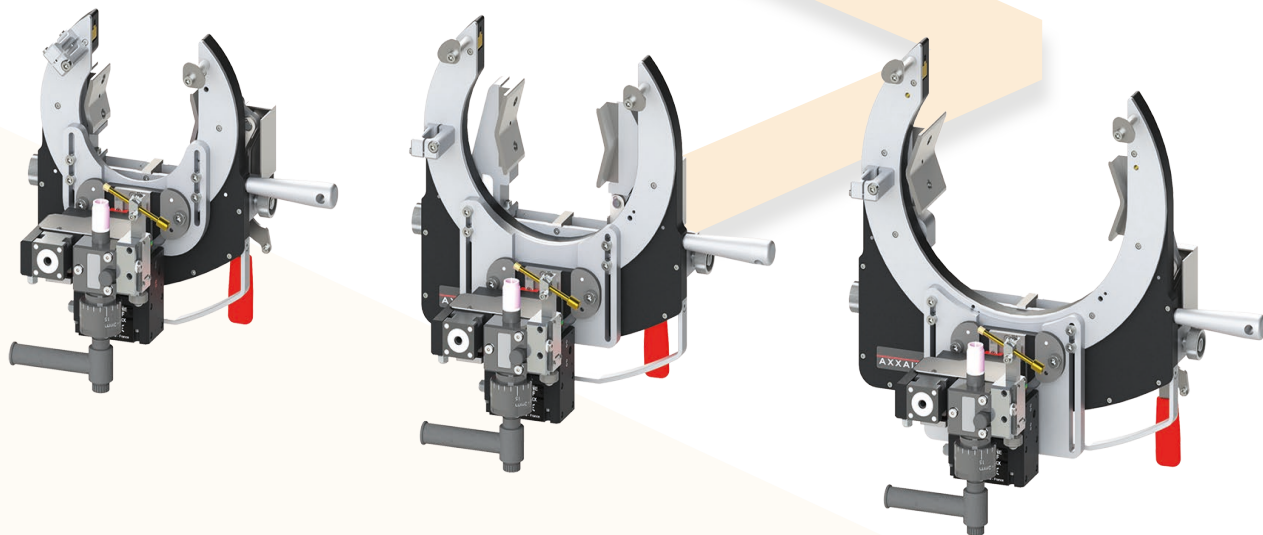

Moteur	Cooling	Product code	Welding machine for tubes of the following diameters (in mm)	Net weight
<b>Angled motor</b>	<b>WATER</b>	SATO-115E52	ø 19 - ø 115 mm	10.6 kg
		SATO-170E52	ø 25 - ø 170 mm	12.7 kg
		SATO-220E52	ø 38 - ø 220 mm	15.1 kg
<b>Straight Motor</b>	<b>WATER</b>	SATO-115E51	ø 19 - ø 115 mm	10.6 kg
		SATO-170E51	ø 25 - ø 170 mm	12.7 kg
		SATO-220E51	ø 38 - ø 220 mm	15.1 kg





# Orbital welding (open heads) - Accessories

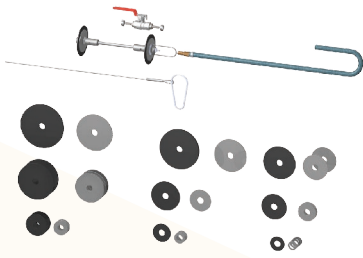

Product Code	Description	Net weight	Packaging (in cm)
SKIF-01	Gas protection KIT	4.5 kg	35 x 30 x 9.5

**Gas membrane protection KIT for tubes Ø 40 to 120 mm**  
 - consists of: 9 sets of membranes with washers, 1 gas pipe 6 m,  
 1 metal cable, 1 ¼ turn gas valve, 1 carabiner

*Inerting the tubes during welding allows more gas savings  
 as we only inert the area to be welded.*

✓ SATO-40E4x	✓ SATO-80E4x	✓ SATO-115E4x	✓ SATO-170E4x	✓ SATO-220E4x	✓ SATO-115E5x	✓ SATO-170E5x	✓ SATO-220E5x
--------------	--------------	---------------	---------------	---------------	---------------	---------------	---------------

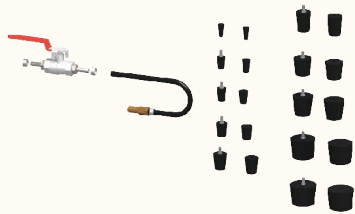

Product Code	Description	Net weight	Packaging (in cm)
SKIB-01	Gas protection KIT	1.7 kg	35 x 30 x 9.5

**Gas plug protection KIT for tubes Ø 6 to 41 mm**  
 - Consists of: 10 sets of perforated plugs, 1 gas inlet connector,  
 1 hose Ø 4/6 length 5 metres

*Facilitates and accelerates inerting. Avoids the use of adhesive paper.*

✓ SATO-40E4x	✓ SATO-80E4x	✓ SATO-115E4x	✓ SATO-170E4x	✓ SATO-220E4x	✓ SATO-115E5x	✓ SATO-170E5x	✓ SATO-220E5x
--------------	--------------	---------------	---------------	---------------	---------------	---------------	---------------

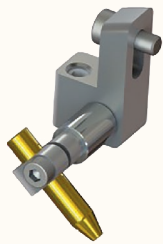

Product Code	Description	Net weight	Dimensions (in mm)
SATOB-02B	Two axis wire guide	0.05 kg	51 x 90 x 65

**SATO Two axis wire guide:**  
 - For use with the SAXX power sources

✓ SATO-40E4x	✓ SATO-80E4x	✓ SATO-115E4x	✓ SATO-170E4x	✓ SATO-220E4x	SATO-115E5x	SATO-170E5x	SATO-220E5x
--------------	--------------	---------------	---------------	---------------	-------------	-------------	-------------



Product Code	Description	Net weight	Dimensions (in cm)
SADF2X	Wire dispenser	12 kg	59.7 x 38.4 x 24

**Wire Dispenser for SAXX-200, duct 5 m max:**  
 - Supplied with the SAXX power supply-connection cable and Teflon duct  
 to guide the wire  
 - Drive pressure adjusted by adjustable spring, with handle.

✓ SATO-40E4x	✓ SATO-80E4x	✓ SATO-115E4x	✓ SATO-170E4x	✓ SATO-220E4x	✓ SATO-115E5x	✓ SATO-170E5x	✓ SATO-220E5x
--------------	--------------	---------------	---------------	---------------	---------------	---------------	---------------



# Orbital welding (Open heads) - Accessories



## 5 or 10 metres welding cable extensions



To increase the operating distance between the welding head and the SAXX generator, we offer cable extensions.

The choice of the cable is made according to the cooling of the torch (water or air) and with or without filler metal.

Cooling		Length	Product Code	Net weight	Dimensions (AxBxC in mm)		
WATER	WITHOUT WIRE	5 metres	SAFS-05MX	7 kg	40 x 59 x 25		
		10 metres	SAFS-10MX	14 kg	40 x 59 x 25		
✓ SATO-40E4x	✓ SATO-80E4x	✓ SATO-115E4x	✓ SATO-170E4x	✓ SATO-220E4x	SATO-115E5x	SATO-170E5x	SATO-220E5x

Cooling		Length	Product Code	Net weight	Dimensions (AxBxC in mm)		
WATER	WIRE	5 metres	SAFS-05MXF	7 kg	40 x 59 x 25		
		10 metres	SAFS-10MXF	14 kg	40 x 59 x 25		
✓ SATO-40E4x	✓ SATO-80E4x	✓ SATO-115E4x	✓ SATO-170E4x	✓ SATO-220E4x	SATO-115E5x	SATO-170E5x	SATO-220E5x

Cooling		Length	Product Code	Net weight	Dimensions (AxBxC in mm)		
WATER	WIRE WITH AVC/OSC	10 metres	SAFS-10MOSC	14 kg	40 x 59 x 25		
SATO-40E4x	SATO-80E4x	SATO-115E4x	SATO-170E4x	SATO-220E4x	✓ SATO-115E5x	✓ SATO-170E5x	✓ SATO-220E5x



## Orbital welding (Open head) - Consumables



Our electrodes are specifically sharpened to 20° with a flat.

This increases the life of the electrodes.

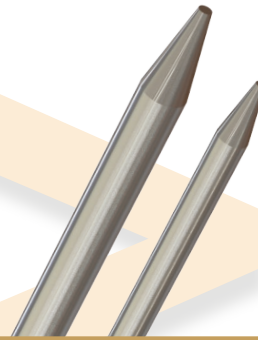

Product Code	Description	Net weight	Plastic box (cm)
SCE16-50	Electrodes	0.02 kg	5.5 x 4.5 x 1
Electrode diameter <b>1.6 mm</b> , length 50mm			
- Box of 10 electrodes			

✓ SATO-40E4x	✓ SATO-80E4x	✓ SATO-115E4x	✓ SATO-170E4x	✓ SATO-220E4x	✓ SATO-115E5x	✓ SATO-170E5x	✓ SATO-220E5x
--------------	--------------	---------------	---------------	---------------	---------------	---------------	---------------



Product Code	Description	Net weight	Plastic box (cm)
SCE24-50	Electrodes	0.05 kg	5.5 x 4.5 x 1
Electrode diameter <b>2.4 mm</b> , length 50mm			
- Box of 10 electrodes			

✓ SATO-40E4x	✓ SATO-80E4x	✓ SATO-115E4x	✓ SATO-170E4x	✓ SATO-220E4x	✓ SATO-115E5x	✓ SATO-170E5x	✓ SATO-220E5x
--------------	--------------	---------------	---------------	---------------	---------------	---------------	---------------



Product Code	Description	Net weight	Plastic box (cm)				
SKTO-01	Replacement torch	0.3 kg	12 x 17.5 x 4				
Replacement kit for open head torch <b>Ø 1.6 mm and Ø 2.4</b>							
- Consists of: 4 long nozzles and 2 short nozzles, 4 electrode clamps, 20 electrodes Ø 1.6 and 20 Ø 2.4 electrodes, 2 Teflon rings, 1 short cap type 9/20 and 1 screw-driver FACOM							
✓ SATO-40E4x	✓ SATO-80E4x	✓ SATO-115E4x	✓ SATO-170E4x	✓ SATO-220E4x	SATO-115E5x	SATO-170E5x	SATO-220E5x

Product Code	Description	Net weight	Plastic box (cm)				
SKTD-02	Replacement torch	0.3 kg	12 x 17.5 x 4				
Replacement kit for straight torch <b>Ø 2.4 mm</b>							
- consists of: 5 nozzles, 2 plugs 9/20, 2 long electrode clamps, 10 electrodes (Ø 2.4) and 2 mesh diffusers							
SATO-40E4x	SATO-80E4x	SATO-115E4x	SATO-170E4x	SATO-220E4x	✓ SATO-115E5x	✓ SATO-170E5x	✓ SATO-220E5x

